

## A GENERAL OVERVIEW ON HYBRID AND ELECTRIC VEHICLES

### **Abstract**

*The economical and environment impacts of fossil energies increased the interest for hybrid, battery and fuel-cell electric vehicles. Several demanding engineering challenges must be faced, motivated by different physical domains integration.*

*This paper aims to present an overview on hybrid (HEV) and electric vehicles (EV) basic structures and features. In addition, it will try to point out some of the most relevant challenges to overcome for HEV and EV may be a solid option for the mobility issue. New developments in energy storage devices and energy management systems (EMS) are crucial to achieve this goal.*

### **Index Terms**

*Hybrid and electric vehicles, batteries and fuel cells, energy management systems.*

### **1. Introduction**

HEV and EV concepts were first introduced at the end of the XIX century. At that time the main efforts were made to improve the internal combustion engine (ICE) features and the autonomy of electric motor (EM) based vehicles. It should be noted that ICE development was in the beginning, while EM technology was in a much higher level: for instance, braking mode was already available, allowing recover the vehicle kinetic energy and storing it in batteries. That was a major contribution for HEV and EV efficiency and autonomy, which is still a fundamental issue for its development, particularly for the last one [1].

In the 1920's there was a huge evolution in the ICE – higher rated power and efficiency with smaller dimensions –, which overcame the EM option. Difficulties on its control, smaller autonomies, higher weight and cost turned out to be fatal for EV development [1].

The energy crises at the end of the 20th century, together with the environment impacts and the awareness of limitations on fossil fuel reservations are the main reasons why hybrid and electric vehicle's interest started to boost once again. In fact, so far they represent the most promising alternative to the classic vehicles based on internal combustion engine (ICE).

It is in the transportation sector that the fossil energy consumption achieves the highest levels, which are increasing every year [1]. Particularly on urban centers, electric vehicle's spreading will be responsible for considerable reductions in the air pollution, as well in noise levels. The green-house gases emissions of fuel electric plants related to the electric vehicles will be much lesser than the ones in ICE vehicles. The main reasons are the electric power train higher efficiency and regenerative braking mode.

Since the 1990 decade hybrid conceptions started to get a general interest, as a consequence of serious difficulties in overcome EV limitations, when compared to ICE based vehicles. Several automobile manufacturers developed different hybrid prototypes, although none of them achieved the commercial stage. The exceptions were the Japanese manufacturers: in 1997, Toyota launched the Prius and Honda released the hybrid versions of Insight and Civic. Since then, other manufacturers started to produce hybrid versions. Presently, the most important car manufacturers offer hybrid vehicles with good dynamic performances and energy consumption [1], [2].

HEV and EV are bringing new engineering challenges, since several different domains (electric motors, power electronics, energy storage devices, control theory, automobile technology) must be integrated, in order to achieve (at least) drivability performances similar to conventional vehicles.

As for the EV development and diffusion, the fundamental issue is still on the energy storage devices, although a lot of work and progress has been made in this field. So far, batteries energy and power densities are in a much lower level than the fuel deposit of a conventional vehicle. As a consequence, the relative short trails in urban centers are presently the ones with higher potential for EV acceptance.

Meanwhile, a considerable amount of effort has been made in fuel cells (FC) development for EV, both by car manufacturers and academic researchers. The biggest challenges to deal with are the energy storage levels so far achieved, manufacturing costs and hydrogen storage and distribution. FC technology is still far from a mature stage, which brings some uncertainty for this option in the future.

This paper is structured as follows: Section 2 presents an overview on HEV (sub-section 2.1) and EV (sub-section 2.2) main features: an emphasis is made on the energy storage devices (batteries and fuel cells), EV EMS's major challenges, different configurations and plug-in vehicles. In Section 3 some conclusions are presented.

## 2. Hybrid and electric vehicles features

Currently, HEVs and EVs are the most promising alternatives to ICE conventional vehicles. The first ones combine ICE together with EM, while in EVs only EMs are present. Energy supply systems for both alternatives include batteries or fuel cells (FCs). Super-capacitors (SC) may also be considered.

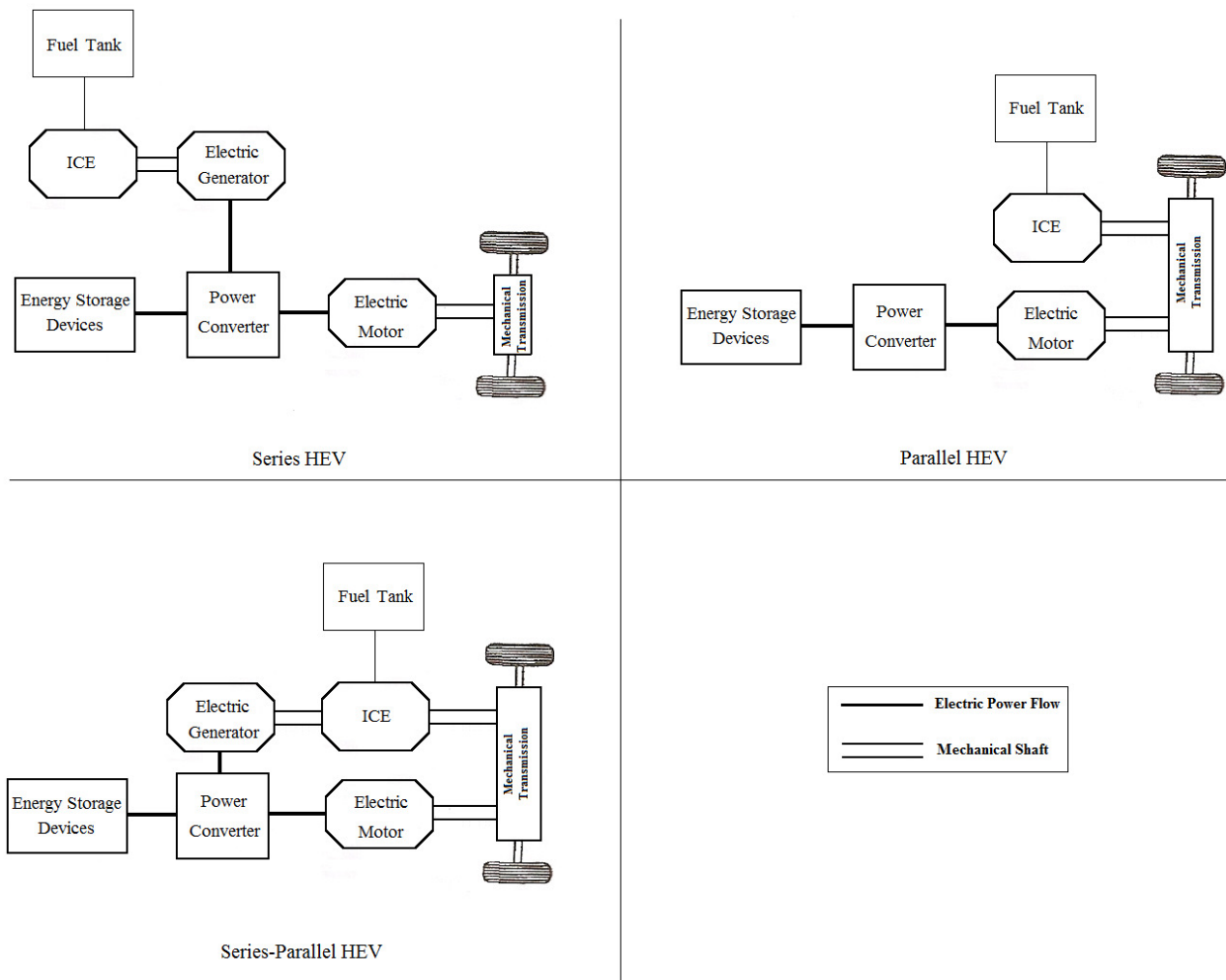

Figure 1 – HEV major configurations

## 2.1. Hybrid Electric Vehicles

HEVs use a combination of ICE and electric motor power train to overcome the disadvantages of both ICE vehicles (demand for oil, green-house gas emissions) and the pure battery-powered electric vehicle (high initial cost, short driving range and long charging time) [3]. HEVs use the electric motor(s) to optimize the efficiency of the ICE, as well to recover the kinetic energy during the vehicle braking. Basically, there are three different configurations, depending on the ICE connection to the electric propulsion system, as depicted in figure 1 [1], [4]:

### 2.1.1. Series HEV

The ICE mechanical output is converted into electricity using a generator, which either charges the battery or is used to propel the wheels through electric motor and mechanical transmission. So, there is no mechanical connection between the ICE and the traction load. The decoupling between the ICE and the driving wheels has the advantage of flexibility for fixing the engine operating states. Nevertheless, it has three propulsion devices (ICE, generator, electric motor). Therefore, the efficiency of series HEV is generally lower.

### 2.1.2. Parallel HEV

It allows both the ICE and electric motor to deliver power in parallel to drive the wheels. Both the ICE and electric motor are generally coupled to the drive shaft of the wheels via two clutches, so the propulsion power may be supplied by the ICE alone, by the electric motor, or by both.

The electric motor can be used as a generator to charge the battery in two ways:

- Regenerative braking;
- Absorbing power from the ICE when its output is greater than that required to drive the wheels.

The parallel hybrid needs only two propulsion devices – ICE and the electric motor. Another advantage over the series case is that a smaller ICE and a smaller electric motor can be used to get the same performances.

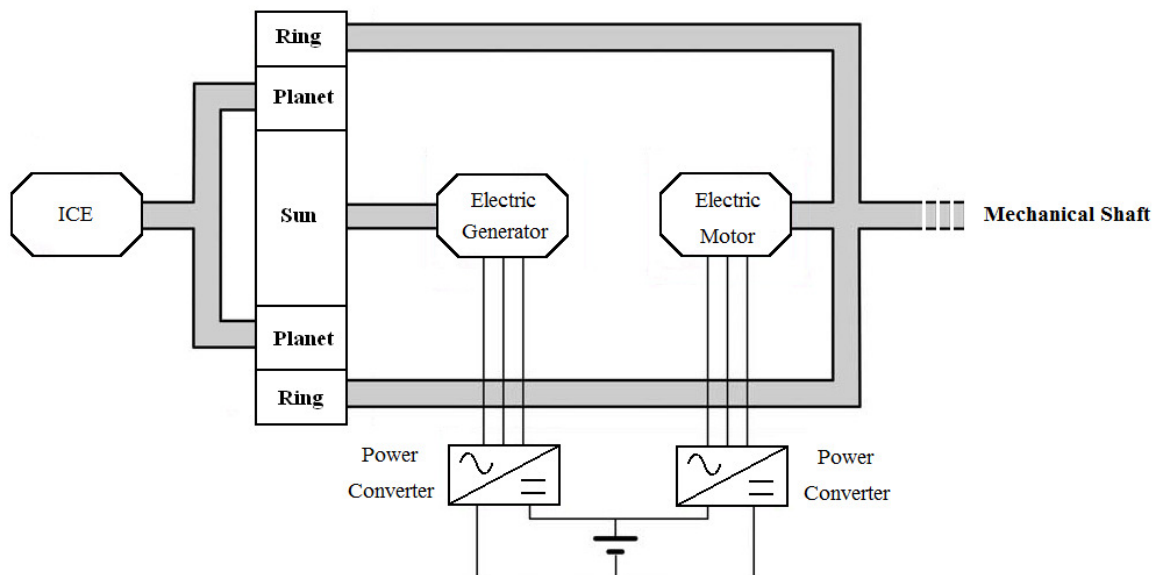

Figure 2 – Planetary gear set [5]

### 2.1.3. Series-Parallel HEV

This configuration incorporates the features of both the series and parallel HEVs, but involving an additional mechanical link and an additional electric machine compared with, respectively, the series hybrid and parallel hybrid. A planetary gear set (figure 2) must be included in the drive-train, in order to allow the mechanical coupling between the three machines and the transmission shaft.

However, the planetary gear set and the three machines make the drive train more complicated, costly and increase the control complexity. In order to reduce the system weight and size, a combination of two concentric electric machines can be used as a power split device, instead of the planetary gear set [4]. Also, in addition, special electromechanical converters were developed: the two electric machines are substituted by a single one, with double rotor – the electric variable transmission concept [5], [6].

### 2.2. Electric Vehicles

EV main obstacles are its high weight and initial cost, battery limited ranges and high charging time, together with small power densities (W/Kg) Nevertheless, several achievements have been made in recent years, both by academic and industry, aiming to the development of new battery devices [7], [10]. Hybrid energy storage systems (e.g. battery + super-capacitor) are also considered, in order to overcome batteries (and fuel-cells) low energy density features. Figure 3 presents an EV basic structure.

There are three fundamental sub-systems:

- Electrical Power Propulsion System;
- Energy Source/Storage System;
- Auxiliary Services System.

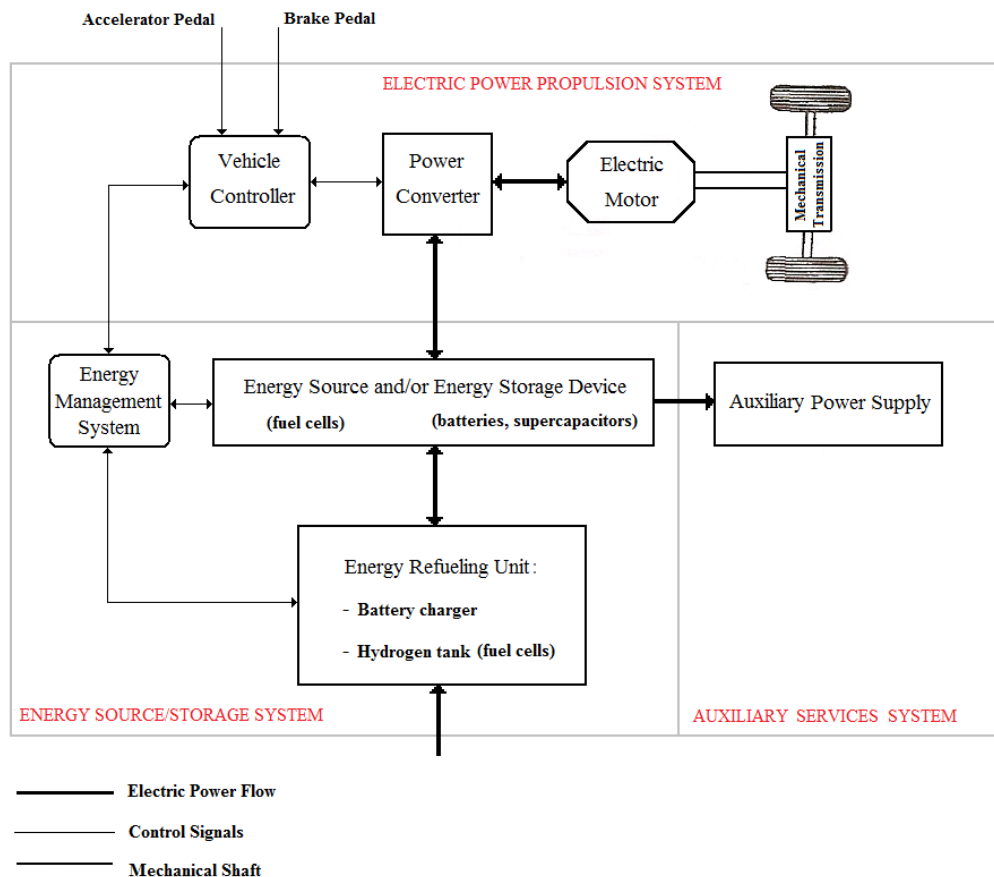

Figure 3 – EV general structure (based in [1])

The electrical power propulsion system includes the vehicle propulsion controller (VPC), static power converter, electric motor(s) and the mechanical power transmission.

The energy storage system includes the energy source and/or storage devices, the energy management system and an exterior interface for energy supply.

The auxiliary services system provides energy for several units, like steering system, ABS, active suspension, air conditioning, etc. They are in every kind of vehicle, conventional, hybrid or pure electric; the number of services included in this system has a clear trend to increase and, of course, its energy needs.

Signals generated by the accelerator and brake pedals are processed by the VPC unit in order to regulate the energy fluxes between the electric motor(s) and the energy storage devices, in both ways. Naturally, the VPC actuates directly on the power converter unit.

The VPC also gets information from the EMS, which has a crucial role in the vehicle's performances: it controls the braking modes and energy storage operations, the energy supply from the exterior, the monitoring of energy storage devices, just to mention some of its mainly tasks.

For EVs there are several electric motor topologies, including more than one motor (see 2.2.4). Regarding to the vehicle energy supply, basically two different options may be considered: Battery Electric Vehicles and Fuel Cell Electric Vehicles.

**2.2.1. Battery Electric Vehicles (BEV)**

Presently, the most common batteries for HEV and EV are Lead Acid (Pb Acid), Nickel Metal Hydride (NiMH), and Lithium Ion (Li-Ion). Particularly, Li-Ion seems to be the most promising option (at the moment they present the highest energy density values). Considering batteries and super-capacitors features (see figure 4), integrating both devices through power electronic converters not only allows to decouple the power (acceleration, braking mode) and energy (cruise speed) functions, providing lower power levels in batteries, but also improves the energy management efficiency in the storage system [8], [9], [10].

Figure 4 shows some relevant facts: batteries features for HEV and Plug-in HEV (PHEV) already reached its goals; however, for pure EV, batteries technology does not fulfill its requirements. Currently, metal-air batteries are the ones with higher potential, both in energy and power density; in addition, they allow a substantial reduction in the battery's weight.

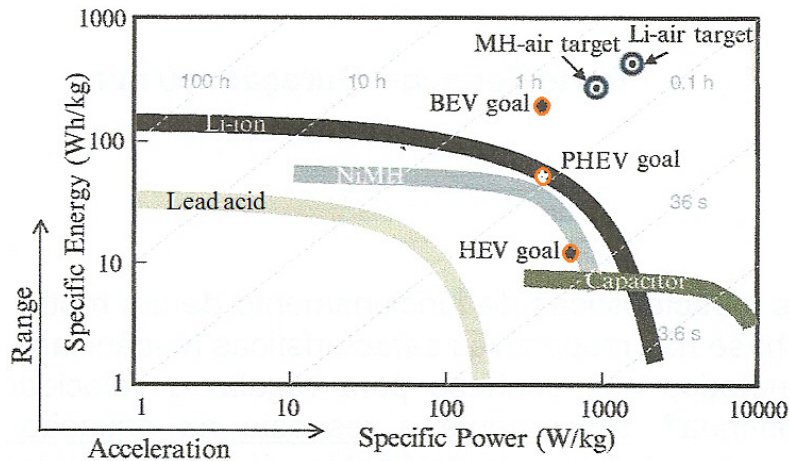

Figure 4 – Batteries and super-capacitors for propulsion [11]

Traction batteries may operate in very aggressive environments (wide temperature ranges, shock and vibration). Besides the hard loading cycles to which they are subjected, a fast aging process may occur (loss of capacity and internal resistance increase) [9]. There are several factors that affect battery performance, such as [10]:

- State of charge (SOC);
- Battery storage capacity;
- Rate of charge/discharge;
- Operation temperature;
- State of health (SOH);
- Age.

Every battery pack must include a management system, not only to monitor and protect the battery and its users, but also for keeping it ready to deliver (or charging) the power demanded by the Energy Management System (EMS). The battery management system (BMS) must pay a special attention to acceleration and braking modes, since the large current and gradient values may destroy the battery pack.

Particularly, lithium battery cells must be operated under tight controlled conditions. These cells are affected by over voltage, over current and temperature, which may lead to irreversible cell damage.

An important challenge in BMS development is also the ability to monitoring the battery SOH in real time. In fact, most of the present methods used for this purpose are time consuming, meaning they are not suitable for online applications [10], [11].

As stated before, the high initial cost of BEVs and its weight, its short driving range and long recharging time, together with low power densities and relative low energy density (Wh/Kg), when compared to a conventional fuel tank, are its main drawbacks.

### 2.2.2. Fuel Cell Electric Vehicles (FCV)

FCs generate electrical energy as a result of an electrochemical reaction based on hydrogen (nonpolluting fuel, with high energy content per unit of weight). ; FCs reaction's product is water steam. There is an important difference between a FC and a battery: the first one generates (convert) energy, the last one stores it. Some of its advantages are efficient conversion of fuel (hydrogen) to electrical energy, quiet operation, zero or very low emissions and rapid refueling [2], [4].

Fuel cell's produced electricity can be used to provide power to the propulsion motor or stored in batteries or super-capacitors for future use [2].

FCV development is in a considerable lower technologic level than batteries. The future of FCV is dependent on the development of a large scale hydrogen infrastructure – hydrogen economy paradigm; however many authors and experts have a reluctant perspective about a hydrogen based economy [12].

### 2.2.3. EMS for EVs

The EMS is a fundamental component for HEV, BEV and FCV, since the energy flux in the drive-train must be always associated to high efficiency levels, without compromising the vehicle performance constraints.

Since Evs near future (at least) will pass by multiple energy sources and converters, to benefit from the best characteristics of the available energy sources. EMS will have to deal with the necessity of multiple energy sources (hybridization) [13].

Modeling these systems is a fundamental step to achieve efficient EMS. However, it is complex due to the multiple interconnected physical subsystems and its different dynamic interactions [4]. For instance, considering EV, basic drive train structure includes fuel cell and/or batteries, super-capacitors, power converters, electric motors and mechanical transmission [8].

Due to system's complexity, EMSs should be considered at two different levels [4]:

- Local energy management for each subsystem, in real time;
- Global energy management, at system level to coordinate the power flow in each subsystem and supervising the whole system.

Designing EMSs with good efficiency in different scenarios determined by traffic conditions, topography and driver characteristics, is a hard task, particularly for real-time applications. With the availability of traffic information from global positioning systems (GPS), mobile phones, and geographic information systems (GIS), predictions of the vehicle propulsion load can be made.

Different EMS structures, together with efficient real-time performance, significantly increase the control task complexity. Modeling and simulation are crucial to achieve efficient EMS, since it allow concept evaluation and prototyping, in a non-expensive and time consuming way. This is determinant for new powertrain configurations and controllers development [3].

**2.2.4. EV Configurations Based on EMs Features**

As stated before, there are several possible configurations for the propulsion system, related to the EM's high flexibility.

In figure 5 are depicted different possibilities, with distinct features [1].

- a) Given the high EM working flexibility, both in low speed (constant torque region) and high speed (flux weakening region), the multi-gear system (unavoidable for ICE vehicles) may be replaced by a simpler system, with a fixed gear. This way, the clutch is eliminated and the size and weight of the mechanical system have a substantial reduction.
- b) The mechanical differential is replaced by an electronic one. Naturally, EM's controllers will adjust both wheel's speed in a coordinate way, particularly in curve paths where wheel speeds are different.

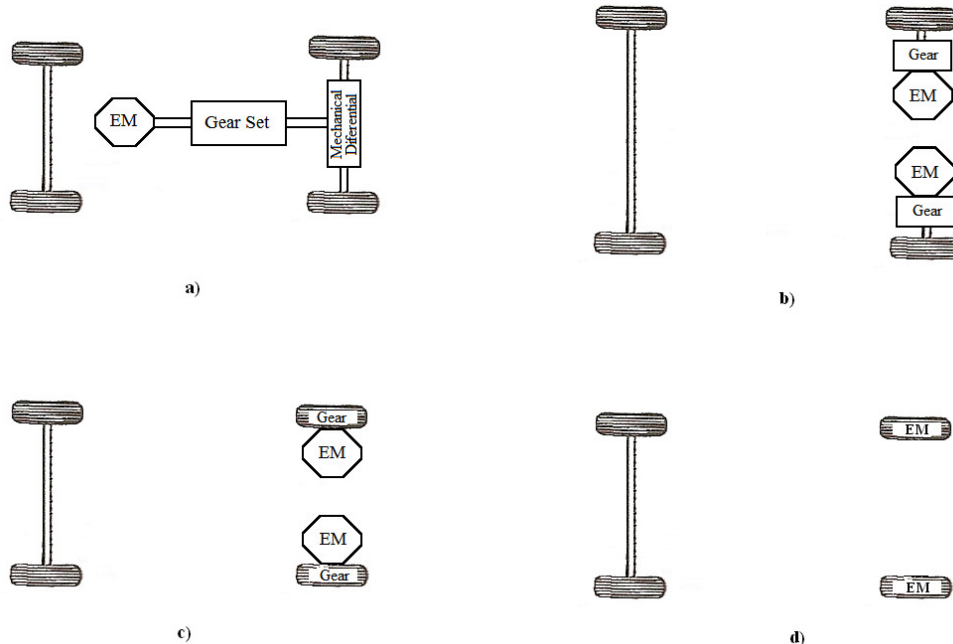

Figure 5 – EV possible configurations

- c) In order to simplify the mechanical transmission, each EM is fixed on the traction wheel through its own gear (in-wheel system). Several issues must be taken into account (motor dimension, weight, robustness, reliability,...).
- d) When compared to c), the gear system is removed. The rotor is directly attached to the wheel, so motors are directly controlled both in torque and speed. In addition to the issues mentioned in c), motor must be able to develop high starting torques, since there is no gear system.

Although EV has zero local emissions, global emissions in battery charge may have a significant impact, depending on the level of green-house utilities for its energy supply.

### 2.3. External Electric Energy Supply – (Plug-in Vehicles)

An external charging system supplies the vehicle's battery.

The propulsion system of Plug-in HEV is similar to the conventional ones. For short distances, only electrical propulsion is activated, meaning that batteries must ensure the energy propulsion; on longer distances, when batteries SOC is below a certain level, the ICE starts working, together with the electric motors (hybrid mode). In both scenarios, Plug-in HEV propulsion is close to pure EV [14]. As a consequence, it should be noted that batteries for Plug-in HEV must have similar features to the ones in EV (usually, these are Plug-in vehicles).

Another relevant possibility for Plug-in vehicles (PV) is that they can be used as energy storage units to serve the grid when they are parked and plugged-in (particularly at night), and supply energy to the grid during day time, helping to achieve a more uniform charge diagram [14].

Table 1 presents a summary of the main characteristics of each kind of vehicle.

Table I – Characteristics of the HEV, BEV and FCV [4]

	HEV	BEV	FCV
Energy Storage Subsystem (ESS)	- Battery - Supercapacitor - Fossil or alternative fuels	- Battery - Supercap.	- H <sub>2</sub> tank - Battery & supercapacitor to enhance power density
Energy Source and Infrastructure	- Gasoline stations - Electrical grid charge facilities (Plug-in hybrid)	- Electric grid charge facilities	- H <sub>2</sub> - H <sub>2</sub> production and transport infrastructure
Characteristics	- Low local emissions - High fuel economy - Dependence on fossil fuel - Long driving range - Higher cost than ICE vehicles	- Zero local emissions - High energy efficiency - Independent of fossil fuel - Relatively short range - High initial cost	- Zero local emissions - High energy efficiency - Fossil fuel independent (if not using gasoline to produce H <sub>2</sub> ) - High cost
Major Issues	- Battery sizing and management - Control, optimization and management of multiple energy sources	- Battery sizing and management - Charging facilities - Cost - Battery lifetime	- Fuel cell cost, life cycle and reliability - Hydrogen production and distribution infrastructure - Cost



### 3. Conclusions

The economical and environment impacts of fossil energies increased the interest for hybrid, battery and fuel-cell electric vehicles. HEV and BEV spreading, particularly in urban centers, will be responsible for considerable reductions in the air pollution, as well in noise levels. The green-house gases emissions of fuel electric plants related to BEV will be much lesser than the ones in ICE vehicles. The main reasons are the electric power train higher efficiency and regenerative braking mode.

The integration of multi-domain efforts (electric motors, power electronics, energy storage devices, control theory, automobile technology) in order to achieve high drivability, safety and reliability performances make HV and EV conception a very challenging engineering task. Modeling and simulation are crucial in order to reach these goals.

EMS's are a fundamental key for vehicle's energy fluxes control with high efficiency levels, particularly in real-time. Also, several vehicle power-train architectures must be considered, which require different energy management approaches.

So far, HEVs have been known a higher development stage: there is already available a considerable commercial set of HEV. Vehicle final cost and the development of efficient EMS are the main challenges to face.

Large efforts are also being made for developing each of BEV's subsystems. The biggest issue is still relying on the batteries features (energy and power densities, charge/discharge cycles and its lifetime, costs). As for the FC, its development stage is far from being a mature one, which, in turn, puts important doubts about its future.

PV in particularly, pure electrical ones, are an important step towards zero emissions goal, particularly with renewable energy sources integration.

However, having in mind battery's state of the art, it is predictable, in the near future, that pure electrical PV will be limited to urban drive scenario (relative short distances).

Finally, it should be pointed out that, besides technical and scientific issues previously discussed, HV and EV future will deeply rely on the integration of multiple social and economy players, like public opinions together with country's government incentives, automotive manufacturers, transport companies, academic research communities and energy utilities.

### References

- [1] Ehsani, Mehrdad, Gao, Yimin, E. Gay, Sebastien, Emadi, Ali (2005). "Modern Electric, Hybrid Electric and Fuel Cell Vehicles – Fundamentals, Theory and Design", CRC Press.
- [2] Chan, C.C. (2007). "The State of the Art of Electric, Hybrid, and Fuel Cell Vehicles", Proceedings of the IEEE, Vol. 95, No. 4, pp. 704-718.
- [4] Letrouvé, T., Bouscayrol, A., Lhomme, W., Dollinger, M., Calvairac, F.M. (2010). "Different Models of a Traction Drive for an Electric Vehicle Simulation". IEEE Vehicle Power and Propulsion Conference (VPPC), September 1-3, France.
- [3] Chan, C.C., Bouscayrol, A., Chen, K. (2010). "Electric, Hybrid and Fuel- Cell Vehicles: Architectures and Modeling", IEEE Transactions on Vehicular Technology, Vol.59, 2, 589--598.
- [5] K. T. Chau and C. C. Chan (2007). "Emerging energy-efficient technologies for Hybrid Electric Vehicle", Proc. IEEE, vol. 95, no. 4, pp. 821–835.
- [6] Hoeijmakers, Martin J., Ferreira, Jan A. (2006). "The Electric Variable Transmission", IEEE Transactions on Industry Applications, Vol.42, No4, pp. 1092-1100.

- [7] Affanni, Antonio et al. (2005). "Battery Choice and Management for New-Generation Electric Vehicles", IEEE Transactions on Industrial Electronics, Vol.52, No5, pp. 1343-1349.
- [8] Guzzella, Lino, Sciarretta, Antonio (2005). "Vehicle Propulsion Systems-Introduction to Modeling and Optimization", Springer, Heidelberg.
- [9] Miller, John M., Startorelli, Gianni (2010). "Battery and Ultracapacitor Combinations – Where Should the Converter Go?", IEEE Vehicle Power and Propulsion Conference (VPPC), September 1-3, France.
- [10] Young, Kwo et al. (2013). "Electric Vehicle Battery Technologies". In: R. Garcia-Valle and J.A. Peças Lopes (eds), Electric Vehicle Integration into Modern Power Networks . (pp.15-56). Springer Science+Business Media New York. ISBN 978-1-4614-0133-9.
- [11] Banaei, Anahita, Fahimi, Babak (2010). "Real Time Condition Monitoring in Li-Ion Batteries via Battery Impulse Response", IEEE Vehicle Power and Propulsion Conference (VPPC), September 1-3, France.
- [12] Neef, H.-J (2009). "International overview of hydrogen and fuel cell research". J. Energy 34, 327--333.
- [13] Silva, M., Trovão, J.P., Pereirinha, P., Marques, L. (2008). "Multiple Energy Sources Monitoring System for Electric Vehicle". SPEEDAM.
- [14] Amjad, Shaik al. (2010). "Review of Design Considerations and Technological Challenges for Successful Development and Deployment of Plug-in Hybrid Electric Vehicles", Renewable and Sustainable Energy Reviews, No14, pp. 1104-1110, Elsevier.

## CURIOSIDADE

